

Actuator

51-
041.006

Distribution by
Mouser



Your product:



51-041.006 Actuator

Loading ...

FRONT

Front dimension: 24 mm x 18 mm

Front form: Rectangular

MOUNTING

Design: Raised

Mounting type: Panel mounting

ELECTRICAL CHARACTERISTICS

Switching voltage and switching current: 100 mA at 42 VAC/VDC

Electric strength: 2500 VAC, 50 Hz, 1 min. between all terminals and earth, according to IEC 61058-1, part 15

MECHANICAL CHARACTERISTICS

Terminal: Universal terminal, 2 x 0.5 mm

Tightening torque: Fixing nut max. 0.5 Nm

Weight: 0.006 kg

AMBIENT CONDITION

IP front protection: IP65, according to DIN EN 60529

Operating temperature: – 25 °C ... + 55 °C, mounted as a block, make sure the heat can escape freely

Storage temperature: – 40 °C ... + 85 °C

Shock resistance: 15 g for 11 ms, as per DIN / EN 60512-4-3, DIN / EN 60068-2-27 (Single impacts, semi-sinusoidal)

CERTIFICATE

REACH: REACH compliant

RoHS: RoHS compliant

OTHER

Short Description: Actuator, 24 mm x 18 mm, Rectangular, Universal terminal, 2 x 0.5 mm, IP65, according to DIN EN 60529

Internal size: 21,5 mm x 15,3 mm

Housing colour: Black

Wiring diagrams:

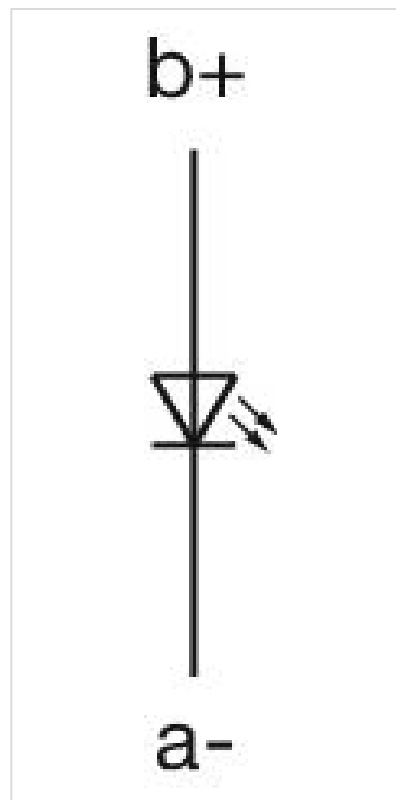

Component layouts:

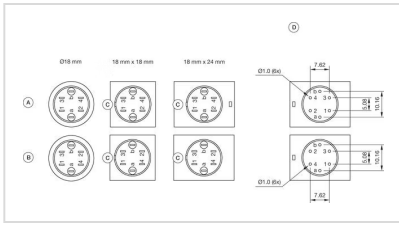

- A = Universal terminal (rear side)
- B = Plug-in terminal (rear side)
- C = Anti twist device
- D = Drilling plan

Mounting cut-outs:

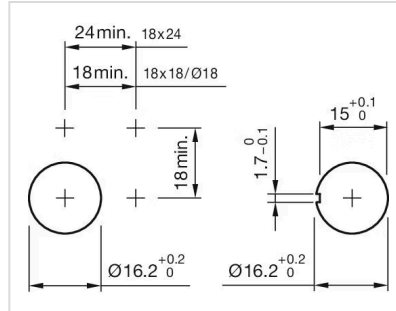

Dimension drawings:

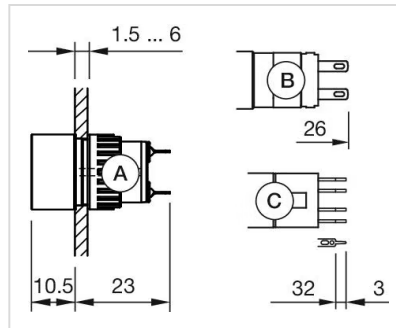

- A = Solder terminal
- B = Plug-in terminal 2.8 mm x 0.5 mm
- C = Universal terminal 2.0 mm x 0.5 mm