

# Actuator

84-0100.0

Distribution by  
Mouser



<https://mouser.eao.com/component/84-0100.0/en...>

Your product:

---



## 84-0100.0 Actuator

*Loading ...*

### FRONT

<b>Front dimension:</b>	Ø 25 mm
<b>Front form:</b>	Round
<b>Front bezel colour:</b>	Black
<b>Front bezel material:</b>	Plastic

### MOUNTING

<b>Design:</b>	Flush
<b>Mounting cut-out:</b>	Ø 22.5 mm
<b>Mounting type:</b>	Panel mounting

### MECHANICAL CHARACTERISTICS

<b>Tightening torque:</b>	Fixing nut 0.8 Nm
<b>Weight:</b>	0.007 kg

### AMBIENT CONDITION

<b>IP front protection:</b>	IP65, IP67
<b>IP Protection:</b>	IP65, IP67
<b>Operating temperature:</b>	- 25 °C ... + 70 °C
<b>Storage temperature:</b>	- 40 °C ... + 85 °C
<b>Climate resistance:</b>	Damp heat, cyclic: 96 hours, + 25 °C/97 %, + 55 °C/93 % relative humidity, as per EN IEC 60068-2-30 Damp heat, steady: 56 days, + 40 °C/93 % relative humidity, according to EN IEC 60068-2-78 Rapid change of temperature: 100 cycles, - 40 °C ... + 80 °C, as per EN / IEC 60068-2-14

### CERTIFICATE

<b>Approbations:</b>	TSI PRM (EBC), NFF
<b>Conformities:</b>	CE, UKCA, 2011 / 65 / EC (RoHS)
<b>REACH:</b>	REACH compliant
<b>RoHS:</b>	RoHS compliant

### OTHER

<b>Short Description:</b>	Actuator, Ø 22.5 mm, Ø 25 mm, Round, Black, Plastic, IP65, IP67
<b>Hints:</b>	Illuminated lens, non-illuminated bezel
<b>Description component:</b>	Material housing actuator: Plastic as per UL94 V0
<b>Wiring diagrams:</b>	

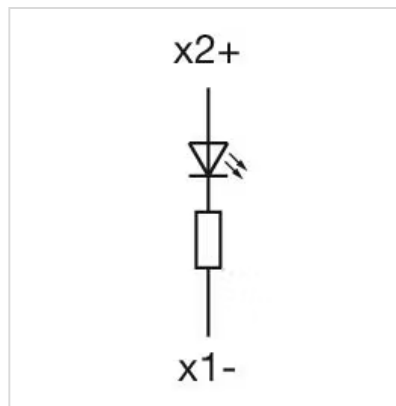

**Mounting cut-outs:**

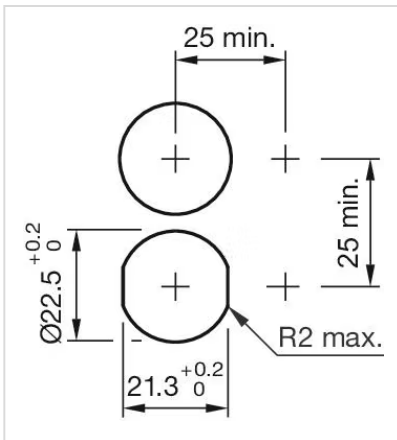

**Dimension drawings:**

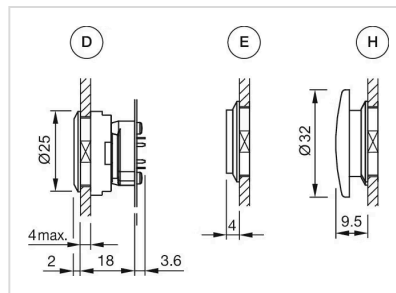

- A = Lens level with bezel
- E = Lens raised above bezel
- H = Mushroom-head cap

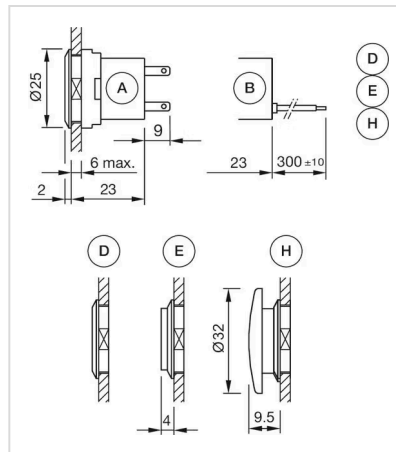

- A = Plug-in terminal 2.8 mm x 0.8 mm
- B = Flat ribbon cable
- D = Lens level with bezel
- E = Lens raised above bezel
- H = Mushroom-head cap